

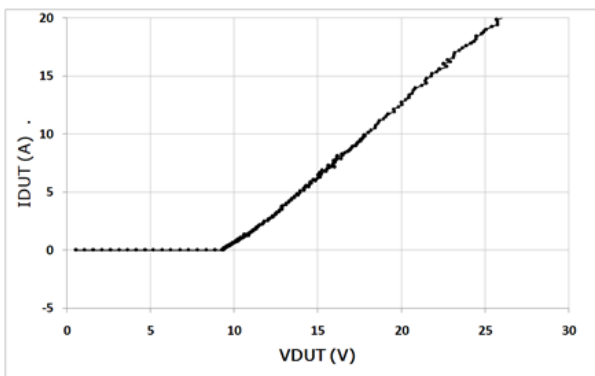

## Electrical Characteristics(@25°C):

Characteristic	Condition	Value		
		Min.	Typical	Max.
ESD per IEC61000-4-2 Contact Discharge			±20kV	
ESD per IEC61000-4-2 Air Discharge			±20kV	
Peak Pulse Power ( $P_{pk}$ )	$t_p=8/20\mu s$		54W	
Reverse Stand-Off Voltage ( $V_{RWM}$ )				5V
Reverse Breakdown Voltage ( $V_{BV}$ )	$I_{BV}=1mA$	6V	8V	
Clamping Voltage ( $V_{CL}$ )	$I_{pp}=1A, t_p=8/20\mu s$	12V		
	$I_{pp}=3A, t_p=8/20\mu s$			18V
Junction Capacitance ( $C_j$ )	$V_{RWM}=0V, f=1MHz$		0.3pF	
Reverse Leakage Current ( $I_{RM}$ )	$V_{RWM}=5V$			1μA

### TLP Measurement



### Voltage Sweeping of I/O\_1 to I/O\_2

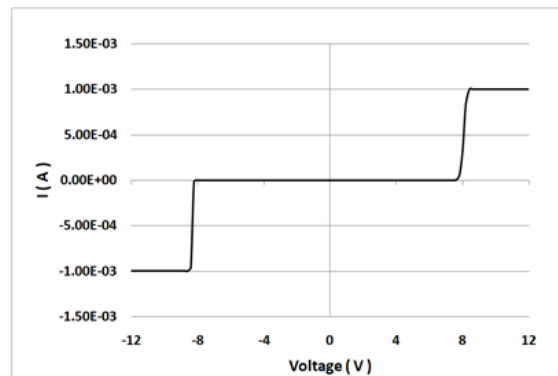

### ESD Clamping of I/O\_1 to I/O\_2 (+8kV Contact per IEC 61000-4-2)

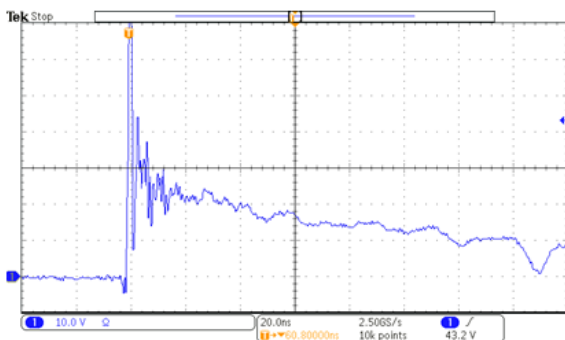

### ESD Clamping of I/O\_1 to I/O\_2 (-8kV Contact per IEC 61000-4-2)

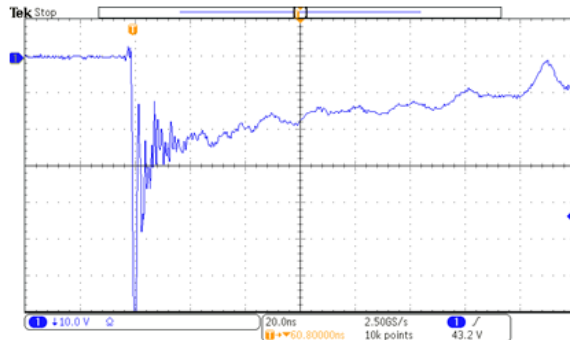

## Packaging Information:

### Reel Dimension:

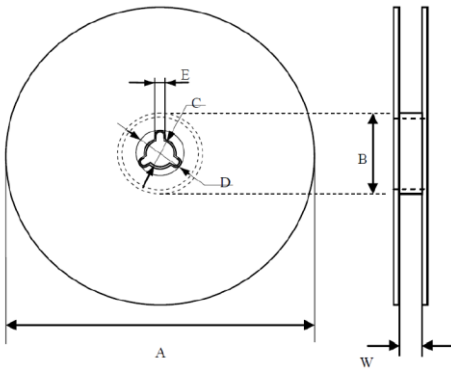

### Packaging Quantity:

Size	1 REEL
	Quantity
0402	10000

Type	A	B	C	D	E	W
7"x8mm	178.0±1.0	60.0±0.5	13.0±0.2	21.0±0.2	2.0±0.5	9.0±0.5

Units: mm

### Tape Dimension / 8mm

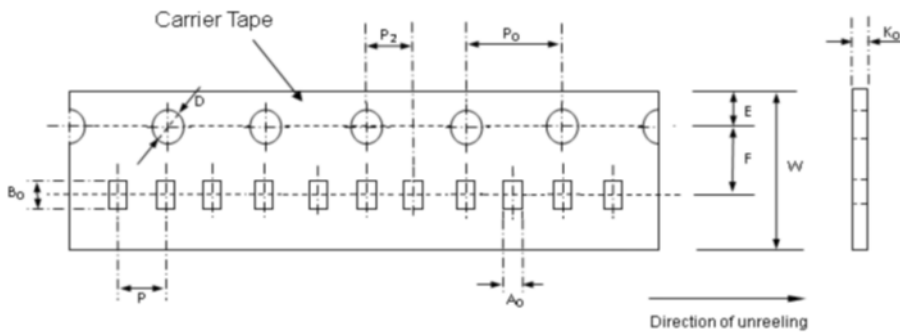

Series	A0	B0	K0	D	P	P2	P0	W	E	F
0402	0.70±0.05	1.12±0.05	0.60±0.05	1.50+0.10/-	2.00±0.10	2.00±0.10	4.00±0.10	8.00±0.10	1.75±0.10	3.50±0.05

Units: mm

## Mechanical Characteristics:

- Case: 0402
- Flammability rating: UL 94V-0
- Packaging: tape and reel
- Polarity: bidirectional

### Circuit Diagram



### Pin Configuration

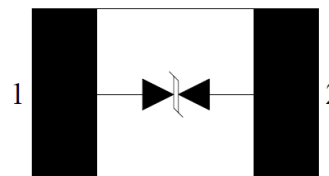

0402 (SGD0402)  
(TOP View)

## Reliability and Test Condition:

Item	Performance Test Condition
<b>High Temperature Reverse Bias (HTRB)</b>	1000 hours at the maximum DC Reverse Voltage rated junction temperature specified in the user/supplier specification. The ambient temperature TA is to be adjusted to compensate for current leakage. TEST before and after HTRB as a minimum. (See note X HTRB.) Test condition: 125±3 °C ; Bias at 80% VBR ; 1000 hours
<b>Temperature Cycling (TC)</b>	1000 cycles (TA = minimum range of -55°C to maximum rated junction temperature, not to exceed 150°C). Can reduce duration to 400 cycles using TA (max) = 25°C-over part maximum rated junction temperature or using TA (max) = 175°C if the maximum rated junction temperature is above 150°C. TEST before and after TC. Test condition: - 55°C / +150°C / 15 minutes ; 1000 cycle
<b>High Humidity High Temp. Reverse Bias (H3TRB)</b>	1000 hours at TA = 85°C/85% RH with part reverse biased at 80% of rated breakdown voltage up to a maximum of 100V or limit of chamber. TEST before and after H3TRB as a minimum. Test condition: 85°C / 85% RH, Bias at VRMW , 1000 hours
<b>Intermittent Operational Life (IOL)</b>	Tested per duration indicated in Table 2A. TA=25°C. Parts powered to insure $\Delta T_J \geq 100^\circ\text{C}$ (not to exceed absolute maximum ratings). TEST before and after IOL as a minimum. Test condition: On=2 minutes Bias at VRWM, Off=2 minutes 15000 Cycle
<b>Autoclave (AC)</b>	96 hours, TA = 121°C, RH = 100%, 15psig. TEST before and after AC. Test condition: 96 hours, TA = 121°C, RH = 100%, 15psig.

## Soldering and Mounting:

### Recommended PC Board Pattern

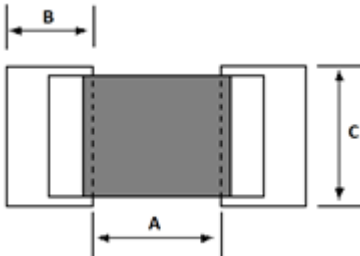

Series	A(mm)	B(mm)	C(mm)
0402	0.3~0.5	0.5~0.7	0.6~0.7

### The IR reflow and temperature of soldering for Pb free process

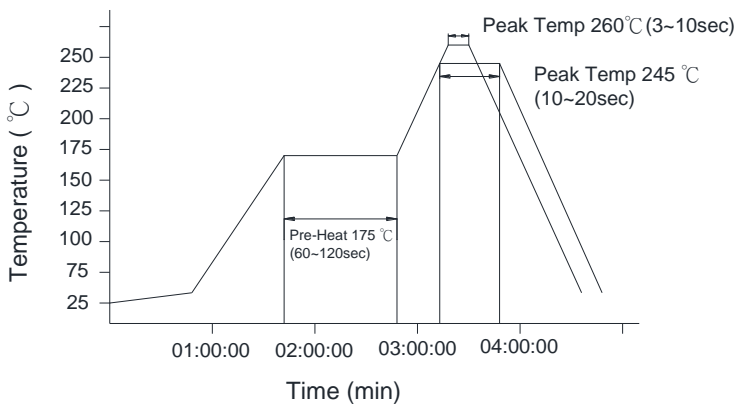

### IR reflow Pb free process suggestion profile

- The solder recommend is Sn96.5/Ag3.5 of 80 to 130 $\mu$ m
- Ramp-up rate (217 $^{\circ}$ C to peak) +3 $^{\circ}$ C/second max.
- Temp. maintain at 175 $\pm$ 25 $^{\circ}$ C 180 seconds max.
- Temp. maintain above 217 $^{\circ}$ C 60~150 seconds
- Peak temperature range 245 +20/-10 $^{\circ}$ C within 5 $^{\circ}$ C of actually peak temperature ( $t_p$ ) 10~20 seconds
- Ramp down rate -6 $^{\circ}$ C/second max.
- Steel plate thickness 0.08~0.10mm

### Hand soldering

In hand soldering of the devices, large temperature gradient between preheated the devices and the tip of soldering iron may cause electrical failures and mechanical damages such as cracking or breakings of the devices. The soldering shall be carefully controlled and carried out, so that the temperature gradient is kept minimum with following recommended conditions for hand soldering.

#### Recommended soldering condition 1 (with preheating)

- Solder  
0.12~0.18mm thread solder (Sn96.5:Ag3.5) with soldering flux in the core  
rosin-based and non-activated flux is recommended.

- Preheating

The devices shall be preheated so that temperature gradient between the devices and the tip of soldering iron is 150 $^{\circ}$ C or below.

- Soldering iron

Rated power of 20W max. with 3mm soldering tip in diameter

Temperature of soldering iron tip 300 $^{\circ}$ C max. 3-5sec (The required amount of solder shall be melted in advance on the soldering tip.)

- Cooling

After soldering, the devices shall be cooled gradually at room ambient temperature.

#### Recommended soldering condition 2 (without preheating)

- Temperature of soldering iron tip 300 $^{\circ}$ C max. 3-5sec
- Solder iron tip shall not directly touch to the devices.
- Solder iron tip shall be fully preheated before soldering while soldering iron tip to the external electrode of the devices.

## Tearing Off Force:

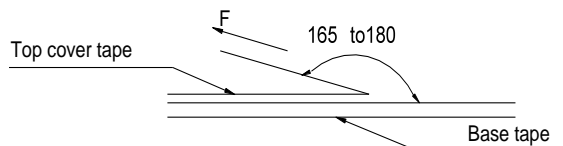

The force for tearing off cover tape is 10 to 100 grams in the arrow direction under the following conditions.

Room Temp. ( $^{\circ}$ C)	Room Humidity (%)	Room atm (hPa)	Tearing Speed mm
5~35	45~85	860~1060	300 $\pm$ 10

## Storage Conditions (Component level):

- Temperature and humidity conditions: Less than 40 $^{\circ}$ C and 60% RH.
- Recommended products should be used within 12 months from the time of delivery.
- The packaging material should be kept where no chlorine or sulfur exists in the air.

## Transportation:

- Products should be handled with care to avoid damage or contamination from perspiration and skin oils.
- The use of tweezers or vacuum pick up is strongly recommended for individual components.
- Bulk handling should ensure that abrasion and mechanical shock are minimized.

*Specifications are subject to change without notice. AEM products are designed for specific applications and should not be used for any purpose (including, without limitation, automotive, aerospace, medical, life-saving applications, or any other application which requires especially high reliability for the prevention of such defect as may directly cause damage to the third party's life, body or property) not expressly set forth in applicable AEM product documentation. It is the customer's responsibility to validate that a particular product with the properties described in the product specification is suitable for use in a particular application. Warranties granted by AEM shall be deemed void for products used for any purpose not expressly set forth in application AEM product documentation. AEM shall not be liable for any claims or damages arising out of products used in applications not expressly intended by AEM as set forth in application AEM product documentation. The sale and use of AEM products is subject to AEM terms and conditions of sale. Please refer to AEM's website for updated catalog and terms and conditions of sale.*